

ADAM-3956

100-pin SCSI DIN-rail Wiring Board

Overview

The ADAM-3956 terminal board provides convenient and reliable signal wiring for PCI-1240/1245/1245E/1245V/1245L/1265/1285/1285E with 100-pin SCSI connector. Its D-SUB 26P type connectors give you the quick and easy way to connect to the Panasonic A5/MINAS A, Yaskawa Sigma 5, Mitsubishi J3S and Delta A2 servo motors.

Features

1. DIN-rail wiring board for PCI-1240/1245/1245E/1245V/1245L/1265/1285/1285E application.
2. Dimensions (W x L x H): 122 x 171 x 45mm (4.8" x 6.73" x 1.77")
3. DB-26 connector
4. LED indicators

Declaration of Conformity

FCC Class A

This equipment has been tested and found to comply with the limits for a Class A digital device, pursuant to part 15 of the FCC Rules. These limits are designed to provide reasonable protection against harmful interference when the equipment is operated in a commercial environment. This equipment generates, uses, and can radiate radio frequency energy and, if not installed and used in accordance with the instruction manual, may cause harmful interference to radio communications.

Operation of this equipment in a residential area is likely to cause harmful interference in which case the user will be required to correct the interference at his own expense.

CE

This product has passed the CE test for environmental specifications when shielded cables are used for external wiring. We recommend the use of shielded cables. This kind of cable is available from Advantech. Please contact your local supplier for ordering information.

Notes

For more information on this and other Advantech products, please visit our websites at:

<http://www.advantech.com>

<http://www.advantech.com/eAutomation>

For technical support and service:

<http://support.advantech.com/>

This startup manual is for the ADAM-3956

Part No: 2003395602

3rd Edition

November 2013

Board Components

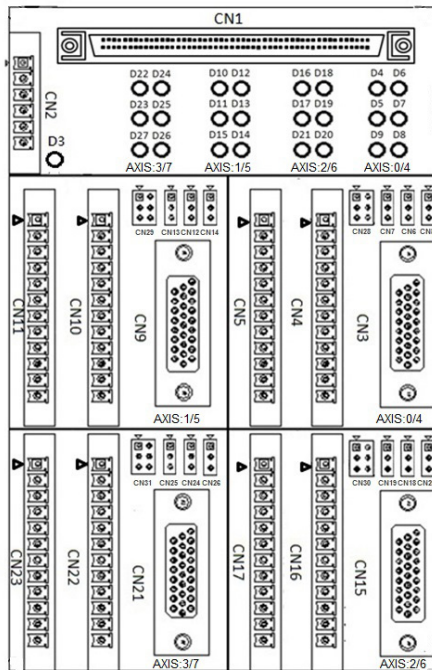

Optional Cables

PCL-101100M-3E SCSI-100 Shielded Cable, 3m

PCL-101100SB-1E Mini-SCSI-100 Shielded Cable, 1m

PCL-101100SB-2E Mini-SCSI-100 Shielded Cable, 2m

PCL-101100SB-3E Mini-SCSI-100 Shielded Cable, 3m

PCL-10153PA5-2E DB26 to SCSI-50 Cable for Panasonic A4/A5, 2m

PCL-10153PA5LS-2E DB26 to SCSI-50 Cable for Panasonic MINAS A, 2m

PCL-10153YS5-2E DB26 to SCSI-50 Cable for Yaskawa Sigma V, 2m

PCL-10153MJ3-2E DB26 to SCSI-50 Cable for Mitsubishi J3S, 2m

PCL-10153DA2-2E DB26 to SCSI-50 Cable for Delta A2, 2m

General Specifications

Input Voltage	Typical	24 V.
	Max.	30 V
	Min.	12 V
Output Voltage	+5 V	
Output Power	2W/70°C; 4W/25°C	
Operating Temperature	0°C to 70°C	
Storage Temperature	-20°C to 85°C	

Component Descriptions and Settings

Note:The pin function is determined by the connected motion card. Take the **PCI-1285/1285E** as an example in this manual.

CN1

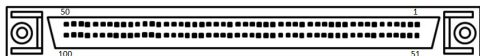

SCSI-100

Pin	Name
1	VEX
2	EMG
3	X0/4_LMT+
4	X0/4_LMT-
5	X0/4_IN1/LTC
6	X0/4_IN2/RDY
7	X0/4_ORG
8	X1/5_LMT+
9	X1/5_LMT-
10	X1/5_IN1/LTC
11	X1/5_IN2/RDY
12	X1/5_ORG
13	X0/4_INP
14	X0/4_ALM
15	X0/4_ECA+
16	X0/4_ECA-
17	X0/4_ECB+
18	X0/4_ECB-
19	X0/4_ECZ+
20	X0/4_ECZ-
21	X1/5_INP
22	X1/5_ALM
23	X1/5_ECA+
24	X1/5_ECA-

25	X1/5_ECB+
26	X1/5_ECB-
27	X1/5_ECZ+
28	X1/5_ECZ-
29	X0/4_IN4 / JOG+
30	X0/4_IN5 / JOG-
31	X1/5_IN4
32	X1/5_IN5
33	GND
34	X0/4_OUT4 / CAM-DO
35	X0/4_OUT5 / CMP
36	X0/4_OUT6 / SVON
37	X0/4_OUT7 / ERC
38	X0/4_CW+ / PULS+
39	X0/4_CW- / PULS-
40	X0/4_CCW+ / DIR+
41	X0/4_CCW- / DIR-
42	GND
43	X1/5_OUT4 / CAM-DO
44	X1/5_OUT5 / CMP
45	X1/5_OUT6 / SVON
46	X0/4_OUT7/ERC/RST
47	X1/5_CW+ / PULS+
48	X1/5_CW- / PULS-
49	X1/5_CCW+ / DIR+
50	X1/5_CCW- / DIR-
51	VEX
52	NC/EMG
53	X2/6_LMT+
54	X2/6_LMT-
55	X2/6_IN1/LTC
56	X2/6_IN2/RDY
57	X2/6_ORG
58	X3/7_LMT+
59	X3/7_LMT-
60	X3/7_IN1/LTC
61	X3/7_IN2/RDY
62	X3/7_ORG
63	X2/6_INP
64	X2/6_ALM
65	X2/6_ECA+
66	X2/6_ECA-
67	X2/6_ECB+
68	X2/6_ECB-
69	X2/6_ECZ+

70	X2/6_ECZ-
71	X3/7_INP
72	X3/7_ALM
73	X3/7_ECA+
74	X3/7_ECA-
75	X3/7_ECB+
76	X3/7_ECB-
77	X3/7_ECZ+
78	X3/7_ECZ-
79	X2/6_IN4 / JOG+
80	X2/6_IN5 / JOG-
81	X3/7_IN4
82	X3/7_IN5
83	GND
84	X2/6_OUT4 / CAM-DO
85	X2/6_OUT5 / CMP
86	X2/6_OUT6 / SVON
87	X2/6_OUT7/ERC/RST
88	X2/6_CW+ / PULS+
89	X2/6_CW- / PULS-
90	X2/6_CCW+ / DIR+
91	X2/6_CCW- / DIR-
92	GND
93	X3/7_OUT4 / CAM-DO
94	X3/7_OUT5 / CMP
95	X3/7_OUT6 / SVON
96	X3/7_OUT7/ERC/RST
97	X3/7_CW+ / PULS+
98	X3/7_CW- / PULS-
99	X3/7_CCW+ / DIR+
100	X3/7_CCW- / DIR-

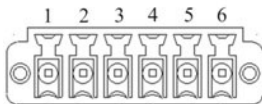

CN2

Pin	Name
1	+VEX
2	-VEX
3	EMG
4	GND
5	+5V (voltage output)
6	-VEX

CN3, CN9, CN15, CN21

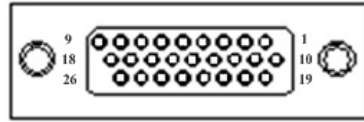

DB-26

Pin	Name	Description
1	SVON	Server on (n SVON)
2	INP	Servo In Position
3	ERC	Servo Error Clear
4	RDY	Servo Ready
5	CW-/PULS-	Output pulse CW-/ Pulse-
6	CW+/PULS+	Output pulse CW+/Pulse+
7	ECA-	Encoder Phase A-
8	ECA+	Encoder Phase A+
9	BREAK+	External Break Signal+
10	RST	Servo Reset
11	ALM	Servo Error Alarm
12	+VEX	External Power (12~24VDC)
13	-VEX	Ground
14	BREAK-	External Break Signal-
15	-VEX	Ground
16	ECB-	Encoder Phase B-
17	ECB+	Encoder Phase B+
18	-VEX	Ground
19	EMG	Emergency Stop
20	-VEX	Ground
21	-VEX	Ground
22	-VEX	Ground
23	CCW-/DIR-	Output pulse CCW-/DIR-
24	CCW+/DIR+	Output pulse CCW+/DIR+
25	ECZ-	Encoder Phase Z-
26	ECZ+	Encoder Phase Z+

CN4, CN10, CN16, CN22

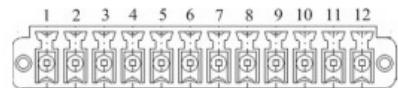

Pin	Name	Pin	Name
1	+VEX	7	CCW+/DIR+
2	ORG	8	CW-/PULS-
3	IN2/RDY	9	CW+/PULS+
4	ECZ+	10	OUT7/ERC/RST
5	ECZ-	11	OUT6/SVON
6	CCW-/DIR-	12	-VEX

CN5, CN11, CN17, CN23

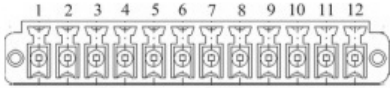

Pin	Name	Pin	Name
1	+VEX	7	OUT4/CAM-DO
2	LMT+	8	OUT5/CMP
3	LMT-	9	BREAK+
4	IN1/LTC	10	BREAK-
5	IN4/JOG+	11	ALM
6	IN5/JOG-	12	-VEX

Jumper Settings

1. For CN6 (Axis 0/4), CN12 (Axis 1/5), CN18 (Axis 2/6) and CN24 (Axis 3/7).

Function: Enable Pin3 of CN3/9/15/21 to **ERC**. (default)

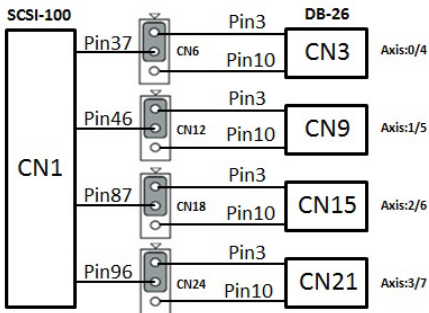

Function: Enable Pin10 of CN3/9/15/21 to **RST**.

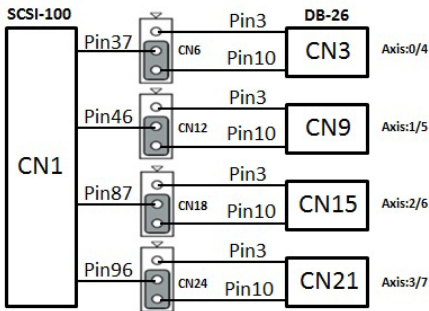

2. For CN7 (Axis 0/4), CN13 (Axis 1/5), CN19 (Axis 2/6) and CN25 (Axis 3/7).

Function: Enable Pin3 (CN4/10/16/22) and Pin4 (CN3/9/15/21) to **RDY**. (default)

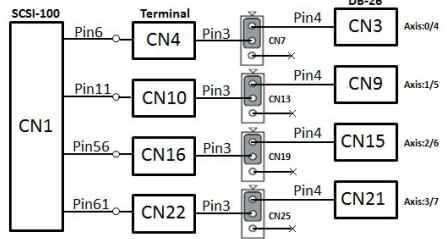

Function: Enable Pin3 of CN4/10/16/22 only to **RDY**.

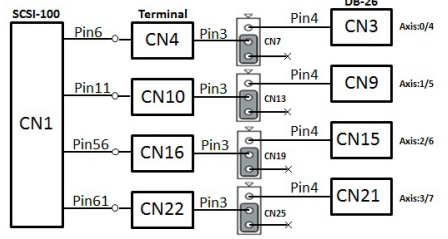

3. For CN8 (Axis 0/4), CN14 (Axis 1/5), CN20 (Axis 2/6), CN26 (Axis 3/7).

Function: Enable Pin11 of CN4/10/16/22 and Pin1 of CN3/9/15/21 to **SVON**. (default)

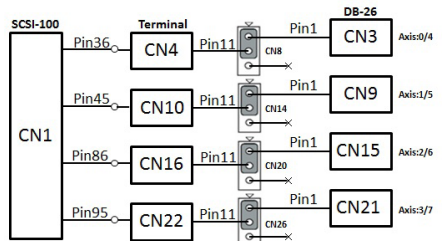

Function: Enable Pin11 of CN4/10/16/22 only to **SVON**.

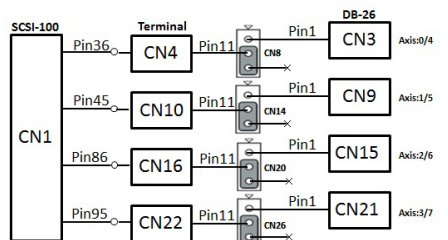

4. For CN28 (Axis 0/4), CN29 (Axis 1/5), CN30 (Axis 2/6) and CN31 (Axis 3/7).

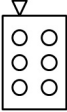
Jumper	Function
	Set pulse-out of CN4/10/16/22 to be in the differential mode.
	Set pulse-out of CN4/10/16/22 to be in the signal-end mode for stepping-motor control. (Pin7 and Pin9 of CN4/10/16/22 are not available)

LED Description

Axis	LED	Description
-	D3	External PWR
Axis 0/4	D4	LMT+
	D5	LMT-
	D6	ORG
	D7	INP
	D8	SVON/OUT6
Axis 1/5	D9	ALM
	D10	LMT+
	D11	LMT-
	D12	ORG
	D13	INP
Axis 2/6	D14	SVON/OUT6
	D15	ALM
	D16	LMT+
	D17	LMT-
	D18	ORG
Axis 3/7	D19	INP
	D20	SVON/OUT6
	D21	ALM
	D22	LMT+
	D23	LMT-
	D24	ORG
	D25	INP
	D26	SVON/OUT6
	D27	ALM